

# HS1V H08 SERIES

## Current Sensor

### Model Number

HS1V 50 H08  
 HS1V 100 H08  
 HS1V 200 H08  
 HS1V 300 H08  
 HS1V 400 H08  
 HS1V 500 H08  
 HS1V 600 H08

Preliminary specification

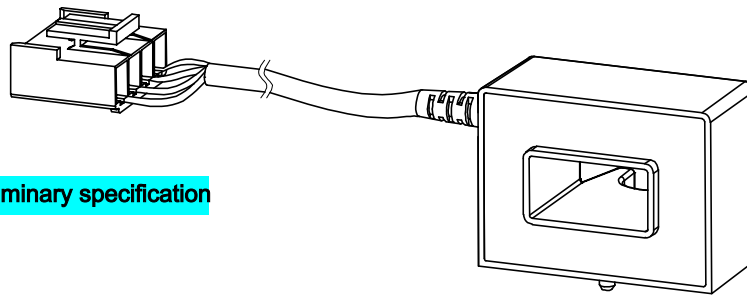

For the electronic measurement of current: DC, AC, pulsed..., with galvanic separation between the primary and the secondary circuits.

### Features

- ✧ Open loop current sensor using the Hall effect
- ✧ Output voltage is proportional to the supply voltage
- ✧ Galvanic separation between primary and secondary
- ✧ Insulating plastic case recognized according to UL 94-V0
- ✧ No insertion losses
- ✧ Small size
- ✧ Standards:
  - IEC 60664-1:2020
  - IEC 61800-5-1:2022
  - IEC 62109-1:2010

### Applications

- ✧ AC variable speed
- ✧ Uninterruptible Power Supply (UPS)
- ✧ Static converters for DC motor drives
- ✧ Switch Mode Power Supplies (SMPS)
- ✧ Power supplies for welding applications
- ✧ Battery management
- ✧ Wind energy inverter

### Safety

This sensor must be used according to IEC61800-5-1.

This sensor must be used in electric/electronic equipment with respect to applicable standards and safety requirements in accordance with the following manufacture's operating instructions.

**Caution, risk of electrical shock!**



When operating the sensor, certain parts of the module can carry hazardous voltage (e.g., Primary busbar, power supply). Ignore this warning can lead to injury and/or cause serious damage.

This sensor is a built-in device, whose conducting parts must be inaccessible after installation. A protective housing or additional shield could be used.

Main supply must be able to be disconnected.

# HS1V H08 SERIES

## Absolute maximum ratings(not operating)

Parameter	Symbol	Unit	Value
Supply voltage	$V_c$	V	±18V
Primary conductor temperature	$T_B$	°C	100

✘ Stresses above these ratings may cause permanent damage.

✘ Exposure to absolute maximum ratings for extended periods may degrade reliability.

## Environmental and mechanical characteristics

Parameter	Symbol	Unit	Min	Typ	Max	Comment
Ambient operating temperature	$T_A$	°C	-40		105	
Ambient storage temperature	$T_S$	°C	-40		105	
Mass	$m$	g		57		

## Insulation coordination

Parameter	Symbol	Unit	Value	Comment
Rms voltage for AC insulation test @ 50Hz, 1min	$V_d$	kV	3.6	According to IEC 60664-1
Impulse withstand voltage 1.2/50µs	$V_w$	kV	6.6	According to IEC 60664-1
Clearance (pri.- sec.)	$d_{cl}$	mm	6.3	
Creepage distance (pri.- sec.)	$d_{cp}$	mm	7.3	
Plastic case	-	-	UL94-V0	
Comparative tracking index	$CTI$	PLC	3	
Application example	-	-	300V CAT III PD2	Reinforced insulation, according to IEC 61800-5-1, IEC 62109-1CAT III, PD2
Application example	-	-	600V CAT III PD2	Basic insulation, according to IEC 61800-5-1, IEC 62109-1CAT III, PD2

# HS1V H08 SERIES

## Electrical data

※ With  $T_A = 25^\circ\text{C}$ ,  $V_C = \pm 15\text{V}$ ,  $R_L = 10\text{k}\Omega$ , unless otherwise noted.

Parameter	Symbol	Unit	Min	Typ	Max	Comment
Primary nominal rms current	$I_{PN}$	A	-50		50	HS1V 50 H08
			-100		100	HS1V 100 H08
			-200		200	HS1V 200 H08
			-300		300	HS1V 300 H08
			-400		400	HS1V 400 H08
			-500		500	HS1V 500 H08
			-600		600	HS1V 600 H08
			Primary current, measuring range*1	$I_{PM}$	A	-150
-300		300				HS1V 100 H08
-600		600				HS1V 200 H08
-900		900				HS1V 300...600 H08
Supply voltage *1	$V_C$	V	$\pm 12$		$\pm 15$	@ 5%
Current consumption	$I_C$	mA		32 0.6		@+15V @-15V
Load resistance	$R_L$	k $\Omega$	10			
Output voltage (Analog) @ $I_{PN}$	$V_{OUT}$	V		$\pm 4.000$		
Electrical offset voltage	$V_{OE}$	mV	-20		20	
Temperature coefficient of $V_{OE}$ *2	$TCV_{OE}$	mV/K	-0.8		0.8	@ -40 $^\circ\text{C}$ ~105 $^\circ\text{C}$
Theoretical sensitivity	$G_{th}$	mV/A		80.00		HS1V 50 H08
				40.00		HS1V 100 H08
				20.00		HS1V 200 H08
				13.33		HS1V 300 H08
				10.00		HS1V 400 H08
				8.00		HS1V 500 H08
				6.67		HS1V 600 H08
Sensitivity error	$\varepsilon_G$	%	-0.5		0.5	exclusive of $V_{OE}$
Temperature of G	$TCG$	%/K	-0.1	$\pm 0.05$	0.1	@ -40 $^\circ\text{C}$ ~105 $^\circ\text{C}$
Linearity error 0... $I_{PN}$	$\varepsilon_L$	% of $I_{PN}$	-0.5	$\pm 0.2$	0.5	exclusive of $V_{OE}$
Hysteresis offset voltage @ $I_P=0$ after $1 \times I_{PN}$	$V_{OM}$	mV	-10	$\pm 4$	10	
Accuracy @ $I_{PN}$	$X$	% of $I_{PN}$	-1		1	exclusive of $V_{OE}$
Response time @ 90% of $I_{PN}$	$t_r$	$\mu\text{s}$		3	5	
Frequency bandwidth (-3dB)	$BW$	kHz	50			

\*1: If  $I_{PN} \leq 300\text{A}$  and powder supply voltage  $V_C = \pm 12\text{V}$  current sensor, measurement range reduced to 2.5 times  $I_{PN}$ .

# HS1V H08 SERIES

Dimensions (in mm. 1 mm = 0.0394 inch)

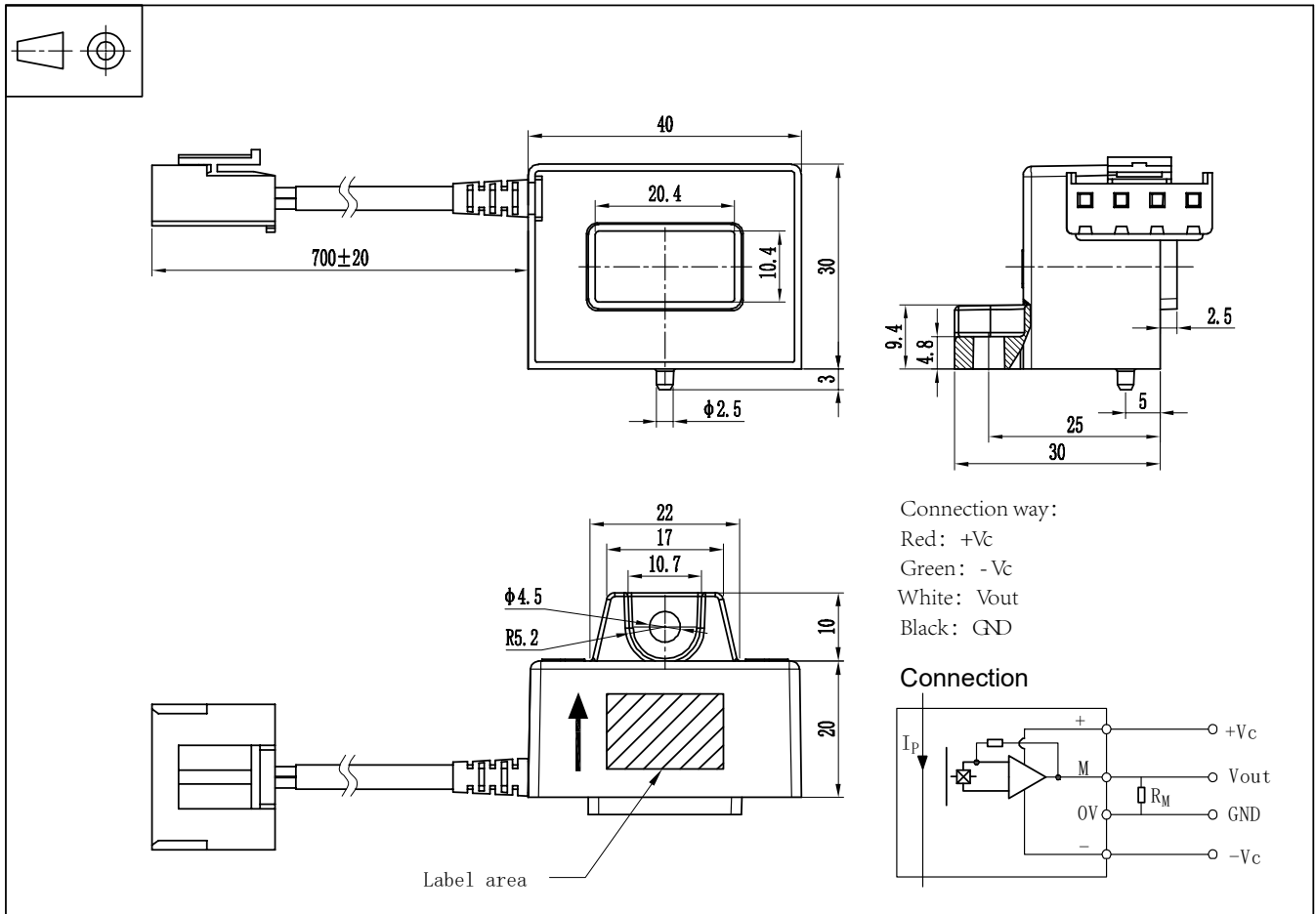

## Mechanical characteristics

◇ General tolerance	$\pm 0.5$ mm
◇ Connection of secondary	RVV4*0.2mm <sup>2</sup>
◇ Terminal type	HC-VH-3.96-4Y
◇ Output line length	$700 \pm 20$ mm
◇ Primary hole	20.4mm×10.4mm
◇ Sensor	1pc $\phi 4.5$ mm through hole 1pc M4 Metal screws

Recommended fastening torque 0.9 N•m ( $\pm 10\%$ )

## Remarks

- ◇  $V_{OUT}$  and  $I_P$  are in the same direction, when  $I_P$  flows in the direction of arrow.
- ◇ Temperature of the primary conductor should not exceed  $105^\circ\text{C}$ .
- ◇ Dynamic performances (di/dt and response time) are best with a single bar completely filling the primary hole.